

PARTS LIST STYKLISTE			
Elektriske og mekaniske komponenter			
Værdi	Komponenter	Stk	Fabrikat
180 Ohm, 10 %, 0,125 W	R 404	1	Beyschlag
1K0 Ohm, 10 %, 0,125 W	R 403	1	..
3K3 Ohm, 10 %, 0,125 W	R 407	1	..
8K2 Ohm, 10 %, 0,125 W	R 401	1	..
6K8 Ohm, 10 %, 0,125 W	R 405	1	..
22K Ohm, 10 %, 0,125 W	R 402	1	..
50 pF, 5 %	C 405, C 406	2	Suflex
650 pF, 5 %	C 407	1	..
22 nF	C 401	1	Ferroperm
100 nF, 20 %	C 403	1	..
10 μF	C 402	1	Evov
BF 167	Q. 401	1	Ducati
			AEG
Spolerør Sp 35/16,5-1908	L 401, L 402	2	Vogt & Co
Klokke K/10/7,7-997FC 1	L 401	1	..
SN 23/85-988 Fi 1e7	L 401 L 402	2	..
Novalsøm	Tegn nr 16.09.652	7	Stocko
Skærmåse	Tegn nr. 24.01.663	1	Nierich
Bundskærm	Tegn nr: 26.01.662	1	HNF
Isolerplade	Tegn nr. 24.01.662	1	HNF
Strømtryk	R 25	1	HNF

MEASUREMENTS MÅLESPECIFIKATIONER

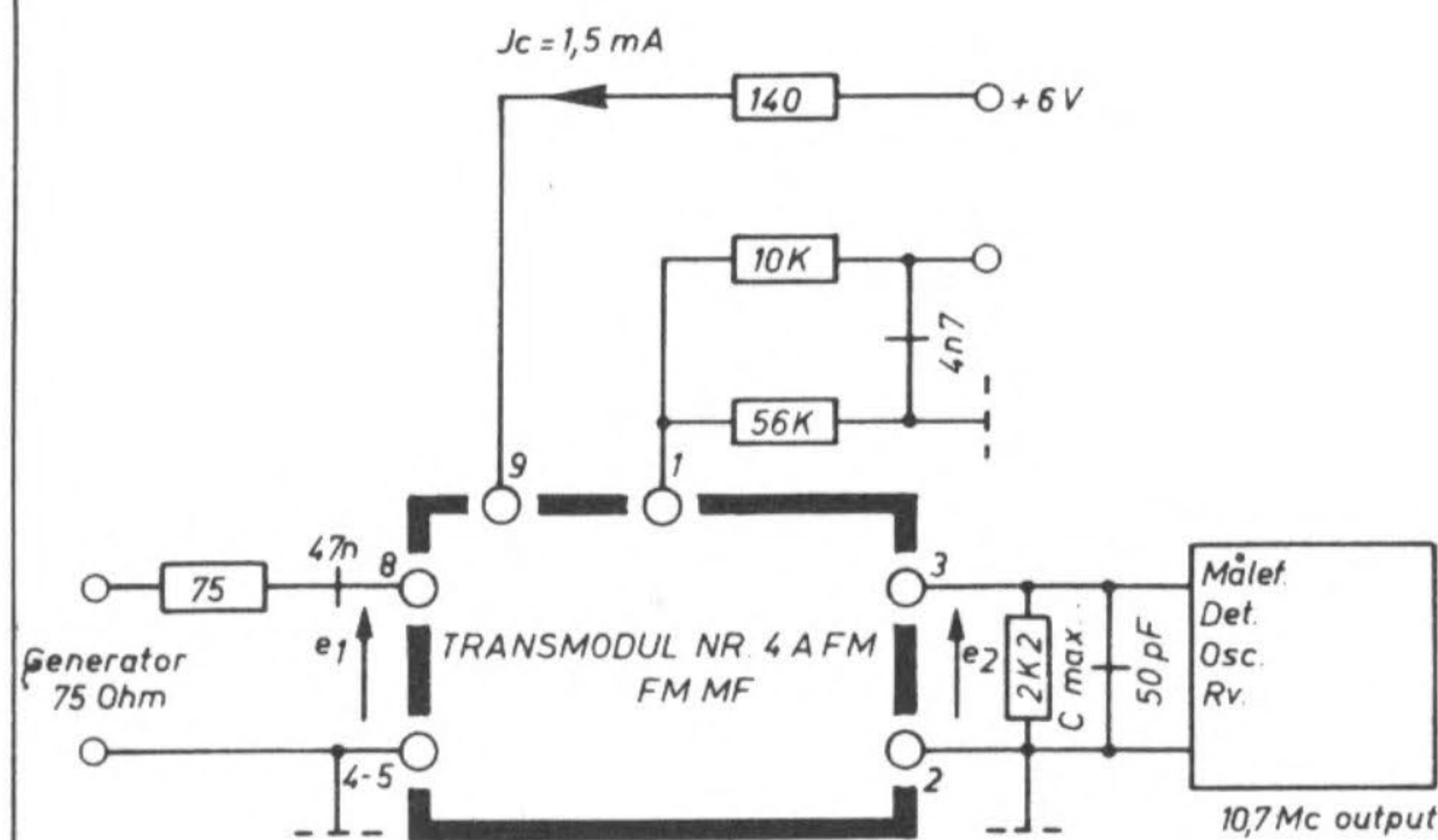

FM 10,7 Mc	
AMPLIFICATION FORSTÆRKNING:	
$\frac{e_2}{e_1} = 22 + 3 - 2 \text{ db}$	
BANDWIDTH BÅNDBREDDE:	
250 Kc ± 30 Kc/s	
MAX. INPUT MAX. INDGANGSSPÆNDING	
5 mV	

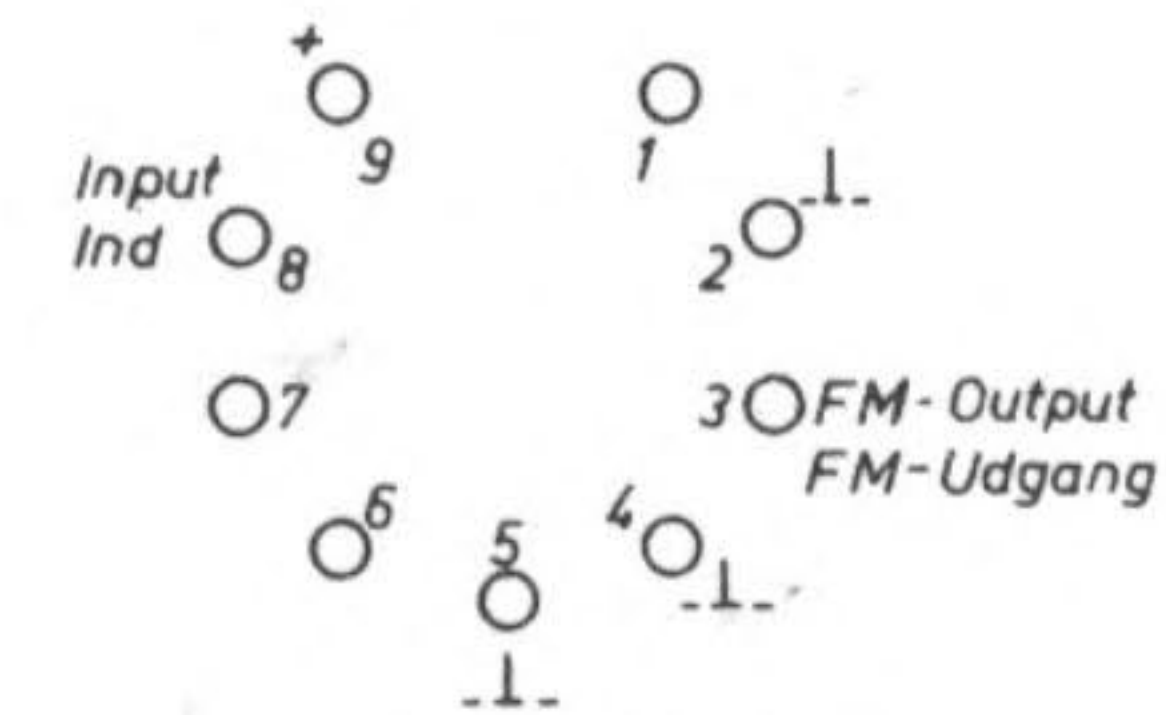

SOCKET CONNECTIONS
Seen from the rear side
of socket

SOKKELFORBINDELSER
Set mod bund af sokkel

FUNKTIONER

FM-IF
UKW-ZF
FM-MF

ARENA
HEDE NIELSENS FABRIKER A/S
HORSENS
TRANSMODUL NR.: 4 A FM

DIAGRAM NR. D-0219

Oktober 1967