

PARTS LIST STYKLISTE			
Elektriske og mekaniske komponenter.			
Værdi	Komponenter	Stk.	Fabrikat
180 Ohm, 10 %, 0,125 W	R 404	1	Beyschlag
220 Ohm, 10 %, 0,125 W	R 403	1	..
3K3 Ohm, 10 %, 0,125 W	R 405, R 407	2	..
8K2 Ohm, 10 %, 0,125 W	R 401	1	..
10K Ohm, 10 %, 0,125 W	R 408	1	..
22K Ohm, 10 %, 0,125 W	R 402	1	..
15K Ohm, 10 %, 0,125 W	R 406	1	..
100pF, 5 %, 30 V	C 405, C 406, C 411	3	Sufler
1nF, 5 %, 30 V	C 404, C 407	2	..
4n7, 40 V	C 409	1	Ferroperm
22nF, 30 V	C 401, C 408	2	..
100nF, 20 %	C 403	1	Evov
10µF, 10/12V	C 402, C 410	2	Ducati
BF 160	Q 401	1	Fairchild
AA123	D 401, D 402	2	Mistral
Spolerør Sp.35/16,5-1909	L 403	1	Vogt & Co.
Spolerør Sp.35/16,5-1908	L 401, L 402	2	..
Klokkek K/10/77-997Fi6a6	L 404	1	..
Klokkek K/10/77-997Fc1	L 401	1	..
SN2,3/85-988 Fi6a6	L 403	1	..
SN2,3/85-988 Fi1e7	L 401, L 402	1	..
Novalsm	Tegn.nr.: 16.09.652	7	Stocko
Skærmåse	Tegn.nr.: 24.01.663	1	Nierich
Bundskærm	Tegn.nr.: 26.01.662	1	HNF
Isolerplade	Tegn.nr.: 24.01.662	1	HNF
Strømtryk	R 25	1	HNF

MEASUREMENTS MÅLESPECIFIKATIONER

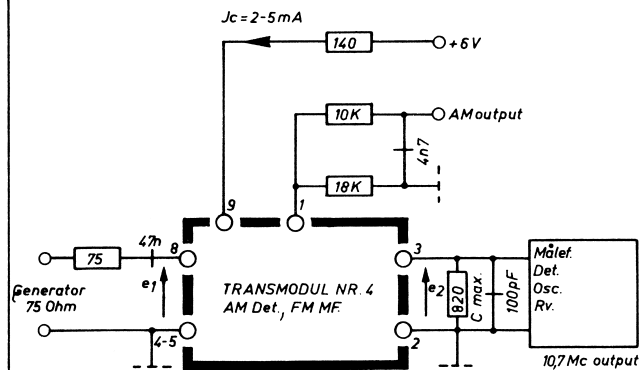

FM 10,7 Mc	AM 452 Kc
AMPLIFICATION FORSTÆRKNING: $\frac{e_2}{e_1} = 23 \text{ db} \pm 2 \text{ db}$	INPUT INDGANGSSPÆNDING 5mV 30% mod.
BANDWIDTH BÅNBREDE: 250 Kc $\pm$ 30 Kc/s	OUTPUT UDGANGSSPÆNDING 50mV $\pm$ 10mV
MAX. INPUT MAX. INDGANGSSPÆNDING 5 mV	

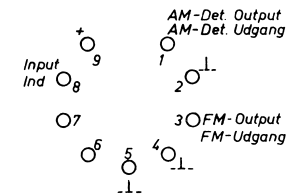

SOCKET CONNECTIONS  
Seen from the rear side  
of socket.

SOKKELFORBINDELSER  
Set mod bund af sokkel

FUNKTIONER

AM-Detector, FM-IF  
AM-Detector, UKW-ZF  
AM-Detector, FM-MF

**ARENA**  
HEDE NIELSENS FABRIKER A/S  
HORSSENS  
**TRANSMODUL NR.:4**

DIAGRAM NR. D-0167

Udfærdiget i September 1966